

规格承认书

SPECIFICATION FOR APPROVAL

客户 CUSTOMER: 深圳矽递科技有限公司

产品编号 PART NO: CSAB0630-100M

客户料号 CUSTOMER NO: _____

科达嘉料号 CODACA NO: CDC-YMA14031932

拟制 PREPARED	审核 CHECKED	批准 APPROVED
陈丽琴	蒋建成	刘洪澎
日期 DATE: 2014-3-5		

客户承认 CUSTOMER APPROVE
日期 DATE: _____

- 1、感谢贵司的支持! 请贵司 7 个工作日内提出修改意见或确认签回, 批量生产供货时, 将按双方确认后的标准执行; 如未签回, 则视为默认, 后续的批量生产供货均按此规格书的标准出货。
- 2、批量生产供货的品质标准依此规格书执行, 发货交期依双方协商一致的结果执行, 产品的环保要求依我司提供的产品环保检测报告为准。
- 3、产品到达贵方后请于40天内使用, 如果有尾数未用完之产品, 请尽量密封保存于温度26℃湿度25-60%RH环境下, 以免电极氧化。

CODACA科达嘉® **深圳市科达嘉电子有限公司**
SHENZHEN CODACA ELECTRONIC CO., LTD

ADD: 广东省深圳市龙岗区坂田街道上雪科技城科技二路永创科技园 2 栋
Building 2, Yongchuang Technology Area, Technology Rd2,
Shangxue Technology Park, Bantian Street, Longgang
District, Shenzhen, China.



RoHS
REACH
ISO9001:2008
ISO14001:2004

TEL: (86)0755-89585372

FAX: (86)0755-89585280

E-mail: codaca@codaca.com.cn

Http: [//www.codaca.com.cn](http://www.codaca.com.cn)

1、特性 Features :

- 使用粉质金属磁芯，具有优良饱和性能；
High performance (Isat) realized by metal dust core.
- 微小体积
Low profile
- 低功耗，低 DCR；
Low power consumption and low DCR.
- 可工作于(1MHz)高频通信环境下；
Capable of corresponding high frequency working environment (1MHz).
- 遵守欧盟 RoHS 标准 100%无铅(Pb)；
100% lead (Pb) free, meet RoHS standard.

2、应用范围 Application :

- 笔记本计算机 CPU 的 DC/DC 转换器；
DC/DC converter for CPU in Notebook PC
- 交换机的面板薄型电流供应模块；
Thin type on-board power supply module for exchanger
- 服务器的 VRM(CPU 的电压调节组件)
VRM for server (the voltage regulation module for CPU).

3、产品编号 Part no :

- (1) 产品类型 Product Type: CSAB 系列
- (2) 外部尺寸 External Dimensions: 6.0mm X 7.1mm X 3.0mm
- (3) 感值 Electrical Code: 100=10uH
- (4) 公差 Inductance Tolerance: M=±20%
- (5) 包装方式 Packaging: R=Reel

CSAB	0630	100	M	R
(1)	(2)	(3)	(4)	(5)

4、外型尺寸与简图 Outline Dimensions and Diagram :

代号 Code	尺寸 Dimensions
L	7.1Max
W	6.0±0.2
T	2.8±0.2
A	1.35±0.3
A'	1.75±0.1
B	2.5±0.5
B'	3.6±0.2
H	0~0.15

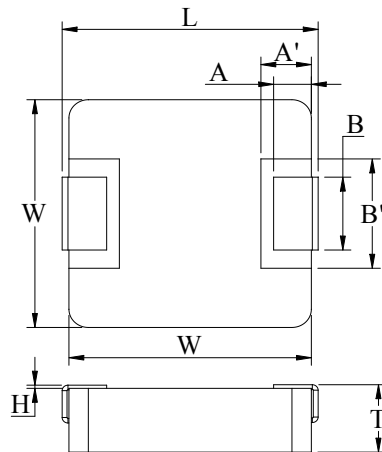

单位 Unit : mm

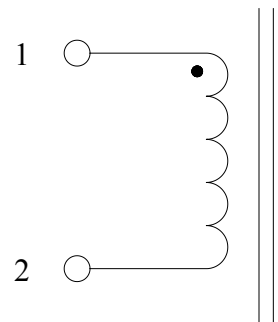

5、标示与代码 Marking and Code :

5.1 标示 Marking:

电感（感值）由 3 位编码标示

The inductor is marked with a 3-digit code.

例 0.56uH 标示为 R56

Example -- 0.56uH → R56



5.2 日期代码 Date Code:

(1)年 Year

举例 Ex: L=2012 年 M=2013 年

(2)周别 Weekly

连续数字 01~52

Serial number : 01 ~ 52

(3)本周内流水包装号 Package Number

A1 A2 A3.....

X	XX	XX
(1)	(2)	(3)

5.3 颜色: 灰色

Colour: Gray

6、推荐(刷锡面)尺寸 Recommend Land Pattern Dimensions :

客户应确保刷锡面尺寸大于以下指数以保证上锡牢固。

The customer shall make sure the land dimensions shown should above confirmed to ensure safety.

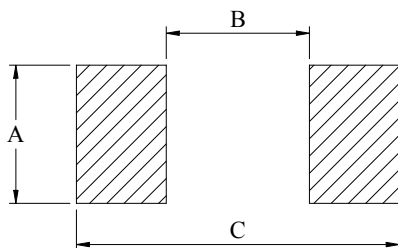

A	3.5
B	3.7
C	8.4

单位: mm

7、规格 Specifications :

产品编号 Part no	0A 感值 L0(μH) L0 Inductance (μH)	R _{dc} (mΩ)		温升直流电流 Idc(A) Heat Rating Current DC Amps. Idc (A)	饱和直流电流 Isat(A) Saturation Current DC Amps. Isat (A)
		典型 Typical	上限 Maximum	典型 Typical	典型 Typical
CSAB0630-100M	10	77.2	96	4.0	5.0

(1): 如您需要其它机种，请联系我们 If you require other model please contact with us.

(2): 感值公差：±20% Inductance Tolerance: ± 20%.

注释:

1: 所有测试数据于 25℃ 室温测取。

All test data is based on 25℃ ambient.

2: Idc : 使产品温升ΔT 约 40℃时所加载的直流电流。

Idc : DC current(A)that will cause an approximate ΔT40℃.

3: Isat : 使产品感值降低约35%时所加载的直流电流。

Isat : DC current(A)that will cause L0 to drop approximately 35%.

4: 工作温度范围：-55℃到+125℃。

Operating temperature range: -55℃~+125℃.

5: 在恶劣的工作环境下，产品局部温度(环境温度+工作温升)不可超过125℃。线路设计, 组件布局, 印刷线路板(PWB)尺寸及厚度，气流及冷却供应均影响产品局部温度。产品局部温度应当在最终应用时再进行验证。

The part temperature (ambient + temp.rise) of the product should not exceed 125℃ in bad working condition. Circuit design component placement, PWB trace size and thickness, airflow and other cooling provisions all affect the part temperature. part temperature should be verified in the final application.

7.1 电流特性 Current Characteristics:

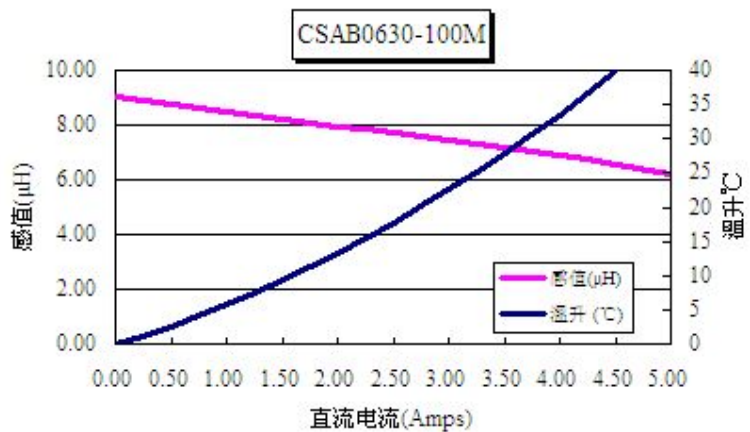

7.2 实测数据 Test Data:

NO	特性数据 Electrical test data			尺寸数据 Dimension data(unit:mm)			
	L(uH)	L(uH)+5.0A	DCR	L	W	T	H
	100KHZ/1.0V		(mΩ)	7.1max	6.0±0.2	2.8±0.2	0~0.15mm
	10±20%	△L≤35%	96max				
1	8.743	6.037	76.29	6.71	6.11	2.82	0.07
2	8.936	6.186	77.49	6.72	6.11	2.79	0.04
3	8.767	6.064	77.00	6.71	6.10	2.79	0.05
4	9.044	6.240	77.38	6.69	6.11	2.82	0.06
5	9.221	6.242	77.11	6.69	6.11	2.82	0.05
6	9.044	6.214	77.00	6.75	6.11	2.76	0.02
7	9.150	6.288	78.09	6.71	6.11	2.81	0.04
8	8.708	6.041	77.07	6.70	6.10	2.79	0.05
9	9.185	6.245	77.24	6.69	6.10	2.79	0.05
10	9.098	6.110	77.56	6.69	6.11	2.82	0.05
MIN	8.708	6.037	76.29	6.69	6.10	2.76	0.02
AVG	8.990	6.167	77.22	6.71	6.11	2.80	0.05
MAX	9.221	6.288	78.09	6.75	6.11	2.82	0.07

8、可靠性 Reliability :

8.1 机械性 Mechanicals:

项目 Item	规格与需求 Specification and Requirement	测试方法 Test Method
可焊性 Solder ability test	沾锡面积不得小于 95%上锡面 Terminals area must have 95%min. solder coverage	上锡升温曲线 Solder heat proof : (1) 预热: 160±10℃持续 90s Preheating : 160 ± 10℃ 90seconds (2) 恒温时段:245±5℃持续 2±0.5s Retention time : 245 ± 5℃ for 2 ± 0.5 seconds
振动测试 Vibration test	感值变化:不超过±5% 且无破裂等机械损伤产生 Inductance change : Within ± 5% Without mechanical damage such as break	(1) 振动频率 Vibration frequency : (10Hz→55Hz→10Hz)60s 作为一个周期 (10Hz to 55Hz to10Hz) in 60 seconds as a period (2) 振动时间 Vibration time: 三维正交坐标系每个方向振动(周期)循环 2 小时 period cycled for 2 hours in each of 3 mutual perpendicular directions (3) 振幅 Amplitude: 1.5 mm Max.
冲击测试 Shock test	感值变化:不超过±5% 且无破裂等机械损伤产生 Inductance change : Within ± 5% Without mechanical damage such as break	(1) 最大振幅 Peak value: 100G (2) 脉冲波长 Duration of pulse: 11ms (3) 三维正交坐标系每个方向正负方向冲击 3 次 times in each positive and negative direction of 3 mutual perpendicular directions

8.2 耐久性 Endurance:

项目 Item	规格与需求 Specification and Requirement	测试方法 Test Method
冷热冲击 Thermal shock	感值变化:不超过±5% 且外观无明显破裂产生 Inductance change : Within ± 5% Without distinct damage in appearance	(1) 重复以下 100 个循环 Repeat 100 cycle as follow (-55±2℃,30±3 分钟)→(室温,5 分钟) (-55 ± 2℃,30 ± 3minutes) → (Room temperature, 5 minutes) →(+125±2℃,30±3 分钟) →(+125 ± 2℃,30 ± 3minutes) →(室温,5 分钟) →(Room temperature, 5 minutes) (2) 恢复: 测试于标准条件下恢复 48+4/-0 小时(参考注释 1) Recovery : 48 + 4 / - 0 hours of recovery under the standard condition after the test. (See Note1)
耐高温测试 High temperature life test	感值变化:不超过±5% 且外观无明显破裂产生 Inductance change : Within ± 5% Without distinct damage in appearance	(1) 环境条件: 85±2℃ Environment condition :85 ± 2℃ 应用电流: 额定电流 Applied Current : Rated current (2) 持续时间: 1,000+4/-0 小时(参考注释 1) Duration : 1,000 + 4 / - 0 hours(See Note1)
耐湿测试 Humidity Resistance	感值变化:不超过±5% 且外观无明显破裂产生 Inductance change : Within ± 5% Without distinct damage in appearance	(1) 环境条件: 60±2℃ RH Environment condition :60 ± 2℃ 湿度: 90~95 % Humidity :90~95 % 应用电流: 额定电流 Applied Current : Rated current (2) 持续时间: 1,000+4/-0 小时(参考注释) Duration : 1,000 + 4 / - 0 hours (See Note1)
低温存放测试 Low temperature life test	感值变化:不超过±5%. 且外观无明显破裂产生 Inductance change : Within ± 5% Without distinct damage in appearance	(1) 存储温度 Store temperature: -55±2℃下存放 1,000+4/-0 小时 -55 ± 2℃ for total 1,000 + 4 / - 0 hours
高温存放测试 High temperature life test	感值变化:不超过±5%. 且外观无明显破裂产生 Inductance change : Within ± 5% Without distinct damage in appearance	(1) 存储温度 Store temperature: +125±2℃下存放 1,000+4/-0 小时 +125 ± 2℃ for total 1,000 + 4 / - 0 hours

注释 1: 关于测试结果的注释: 测试应于标准条件下恢复 48±2 小时后进行。

9、包装 Packaging :

9.1 尺寸 Dimensions:

9.1.1 包装料袋尺寸 Tape packaging dimensions:

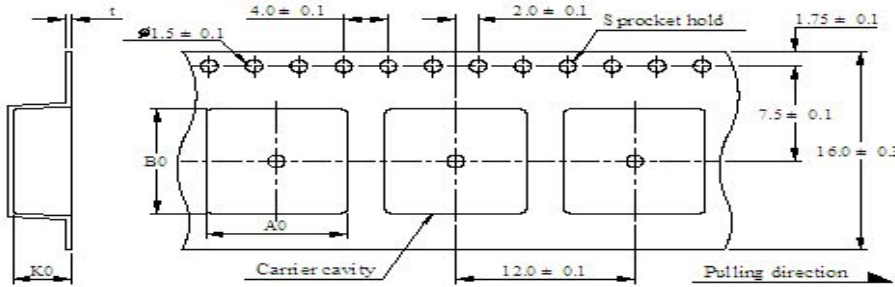

	A0	B0	KO	T
mm	8.0±0.1	7.1±0.1	3.8±0.1	0.4±0.05

9.1.2 卷轴尺寸 Reel dimensions:

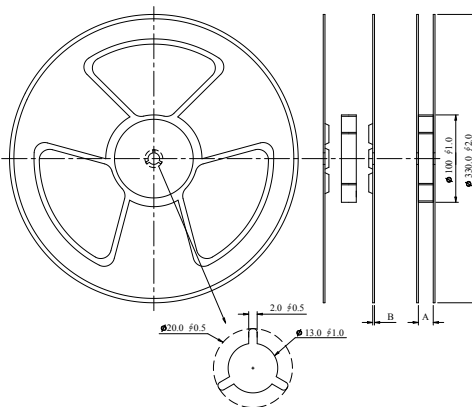

	A	B
mm	17.1±0.3	2.1±0.3

9.1.3 外箱尺寸 Carton dimensions:

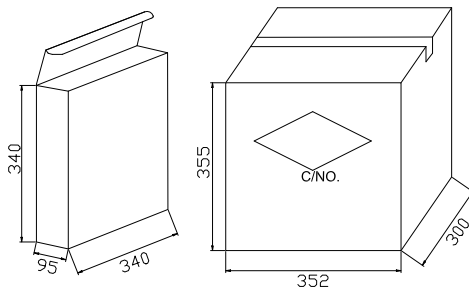

型号 Type	数量 (单位: mm) Quantities(Unit:mm)	数量 (单位: mm) Quantities(Unit:mm)	数量 (单位: mm) Quantities(Unit:mm)
	卷 Reel	内盒 Inner Carton	外箱 Outer Carton
CSAB0630	1000PCS	3*1000PCS	3*3000PCS

9.2 上盖剥离拉力 Peel force of top cover tape:

剥离速度应控制于 300 mm/分 The peel speed shall be about 300 mm/minute.

上盖剥离拉力介于 0.2~1.3 牛 The peel force of top cover tape shall be between 0.2 to 1.3 N.

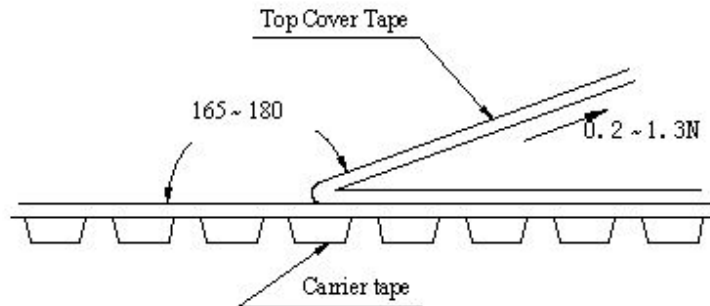

9.3 标签标识 Label marking:

以下项目须明确标识于料盘之产品卷标及运输卷标上。

The following items shall be marked on the reel of production and shipping Label.

9.3.1 产品卷标 Production Label:

- (1) 机种 Part No.
- (2) 产品电性信息 Electrical information.
- (3) 数量 Quantity.
- (4) 包装流水号. Packing No.

9.3.2 运输标签 Shipping Label:

- (1)*客户名称* Customer's name.
- (2)*客户需求机种* Customer's part No.
- (3) 供应商编码 Supplier's part No.
- (4) 供应商名称 Supplier's name.
- (5) 产品产地(供应商所在地) Country of origin.

注释: 项目(1)和(2)为必填项 Note : Item (1) and (2) are must filled.

10、注意事项 Care Notes :

10.1 使用注意事项 Care notes for Use:

(1) 存储条件 Storage Condition:

温度 25~35℃, 湿度 45~85%RH Temperature: 25 to 35℃, Humidity: 45% to 85% RH.

(2) 使用温度 Working Temperature:

a. 最低温度: -55℃产品环境温度。

Minimum Temperature: -55℃ Ambient temperature of power choke coil.

b..最高温度: +125℃含环境温度及产品温升。

Maximum Temperature : +125℃ The value of temperature including ambient of the transformer and temperature rise of power choke coil.

c. 在可靠性测试中, 本品可在-55℃~+125℃中正常使用。

There is not a problem from -55℃ ~ +125℃ in a reliability test.

d. 尽管如此, 本品不承诺 UL 温度等级保证书中保证条款(美国保险商实验所)。

However, this does not fully apply the guaranteed temperature on UL.

(3) 模式 Model:

当本产品应用于相似或新的产品上时, 电性可能因使用条件的不同而与规格产生一定出入。

When this power choke coil was used in a similar or new product to the original one, sometimes it might be unable to satisfy the specifications due to different condition of usage.

(4) 跌落 Drop:

本产品受到跌落等机械外力损伤时, 产品特性可能会变差(因为损伤到线圈等)。

禁止使用以上外力损伤之电感。

The dropping or mechanical stress of power choke coil may decrease the characteristics for the coil bobbin may be damaged. Such damaged coils are not suggested to use.

10.2 安全注意事项 Safety Caution:

(1) 预防不正常条件 Provision to Abnormal Condition:

在过载、短路、开路等不正常条件下, 本电感产品无任何自我保护功能。

因此, 请确保成品使用中不含烟、火、高压、绝缘等危险使用条件, 并提供在不正常条件下的保护作用装置或电路。

This power choke coil itself does not have any protective function in abnormal condition such as overload, short-circuit, open-circuit conditions, etc.

Therefore, it shall be confirmed as the end product where there is no risk of smoking, fire, dielectric withstand voltage, insulation resistance, etc. in abnormal conditions to provide protective devices and/or protection circuit in the end product.

(1) 温升 Temperature Rise:

电感的温升受成品结构影响，因此，强烈建议您于成品后再次确认电感温升是否符合规定温度等级要求。

Temperature rise of power choke coil depends on the installation condition on end products.

It shall be confirmed on the actual end product that temperature rise of power choke coil is in the limit of specified temperature class.

(1) 绝缘能力 Dielectric Strength:

高电压绝缘测试会对本产品绝缘金属粉体造成损害，并缩短产品寿命。

Dielectric withstanding test with higher voltage than specific value will damage insulating material and shorten its life.

(1) 防水 Waterproof:

本扼流电感产品绝缘性会因工作环境潮湿而下降，因此本产品禁止应用在有水，咖啡及其它液体存在的潮湿环境中。

This power choke coil must not be used in wet condition by water, coffee or any liquid because insulation strength becomes very low in the very condition.

(1) 埋制 Potting:

将本产品用于埋制复合组件时，有可能会对本产品金属表层造成腐蚀，因此，如需将本产品用于埋制生产应用，请致询本公司。

If this power choke coil is potted in some compound, coating material of magnet wire might be occasionally damaged. Therefore, please ask us if you intend to pot this power choke coil.

(1) 清洁剂 Detergent:

本产品所使用的清洗剂需经本公司可靠度等项目严格测试，如需清洗操作，请务必致询本公司。

Please consult our company once in case of this because the confirmation of reliability etc. is needed when the washing medicine is used for the power choke coil.